

SC12CLX.2 LBP Compressor R404A/R507 220-240V 50/60Hz

General

Code number	104L2697
Approvals	EN 60335-2-34, UL984, CCC GB4706.1, GB4706.17
Compressors on pallet	80

Application

Application	LBP			
Frequency	Hz	50	60	
Evaporating temperature	°C	-45 to -10	-45 to -10	
Voltage range	V	198 - 254	198 - 254	
Max. condensing temperature continuous (short)	°C	55 (60)	55 (60)	
Max. winding temperature continuous (short)	°C	125 (135)	125 (135)	

Cooling requirements

Frequency	Hz	50			60		
Application		LBP	MBP	HBP	LBP	MBP	HBP
32°C		F ₂	-	-	F ₂	-	-
38°C		F ₂	-	-	F ₂	-	-
43°C		-	-	-	-	-	-
Remarks on application:							

Motor

Motor type	CSIR		
LRA (rated after 4 sec. UL984), HST LST	A	19.6	-
Cut in Current, HST LST	A	19.6	-
Resistance, main start winding (25°C)	Ω	3.8	13.7

Design

Displacement	cm ³	12.87
Oil quantity (type)	cm ³	550 (polyolester)
Maximum refrigerant charge	g	1300
Free gas volume in compressor	cm ³	1510
Weight without electrical equipment	kg	13.7

Dimensions

Height	mm	A	219
		B	213
		B1	193
		B2	110
Suction connector	location/I.D. mm angle	C	8.2 37°
	material comment		Copper Rubber plug
Process connector	location/I.D. mm angle	D	6.2 37°
	material comment		Copper Rubber plug
Discharge connector	location/I.D. mm angle	E	6.2 37°
	material comment		Copper Rubber plug
Oil cooler connector	location/I.D. mm angle	F	-
	material comment		-
Connector tolerance	I.D. mm		±0.09
Remarks:			

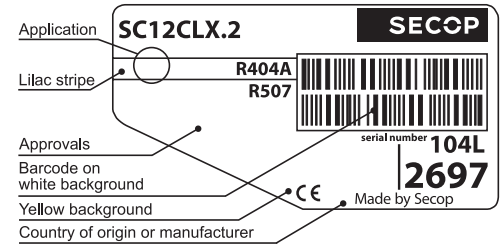

- S = Static cooling normally sufficient
- O = Oil cooling
- F₁ = Fan cooling 1.5 m/s (compressor compartment temperature equal to ambient temperature)
- F₂ = Fan cooling 3.0 m/s necessary
- SG = Suction gas cooling normally sufficient
- = not applicable in this area

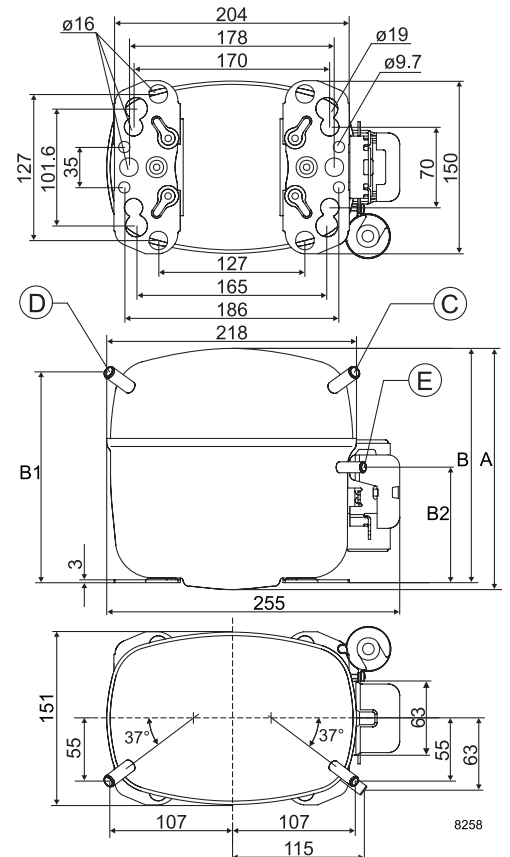

ASHRAE LBP*

 230V, 60Hz, fan cooling F₂

Evap. temp. in °C	-45	-40	-35	-30	-25	-23.3	-20	-15	-10	-6.7	-5	0	5	7.2	10	15	20
Capacity in W	176	283	426	598	739	805	1051	1339	1467								
Power cons. in W	259	329	405	482	536	560	643	732	769								
Current cons. in A	2.31	2.45	2.63	2.84	3.00	3.08	3.35	3.66	3.78								
COP in W/W	0.68	0.86	1.05	1.24	1.38	1.44	1.63	1.83	1.91								

ASHRAE LBP*

 220V, 50Hz, fan cooling F₂

Evap. temp. in °C	-45	-40	-35	-30	-25	-23.3	-20	-15	-10	-6.7	-5	0	5	7.2	10	15	20
Capacity in W	160	247	363	502	616	670	868	1101	1205								
Power cons. in W	256	310	370	430	472	491	555	624	654								
Current cons. in A	2.79	2.89	3.02	3.17	3.29	3.34	3.54	3.75	3.85								
COP in W/W	0.63	0.80	0.98	1.17	1.30	1.36	1.56	1.76	1.84								

EN 12900 Household (CECOMAF)*

 230V, 60Hz, fan cooling F₂

Evap. temp. in °C	-45	-40	-35	-30	-25	-23.3	-20	-15	-10	-6.7	-5	0	5	7.2	10	15	20
Capacity in W	141	233	343	473	626	683	804	1011	1248								
Power cons. in W	255	327	398	469	541	566	615	693	777								
Current cons. in A	2.28	2.43	2.60	2.79	3.01	3.09	3.25	3.52	3.81								
COP in W/W	0.55	0.71	0.86	1.01	1.16	1.21	1.31	1.46	1.61								

EN 12900 Household (CECOMAF)*

 220V, 50Hz, fan cooling F₂

Evap. temp. in °C	-45	-40	-35	-30	-25	-23.3	-20	-15	-10	-6.7	-5	0	5	7.2	10	15	20
Capacity in W	130	205	294	399	522	569	666	834	1026								
Power cons. in W	253	309	365	420	475	495	533	594	659								
Current cons. in A	2.77	2.88	3.00	3.13	3.29	3.35	3.46	3.65	3.86								
COP in W/W	0.51	0.66	0.81	0.95	1.10	1.15	1.25	1.40	1.56								

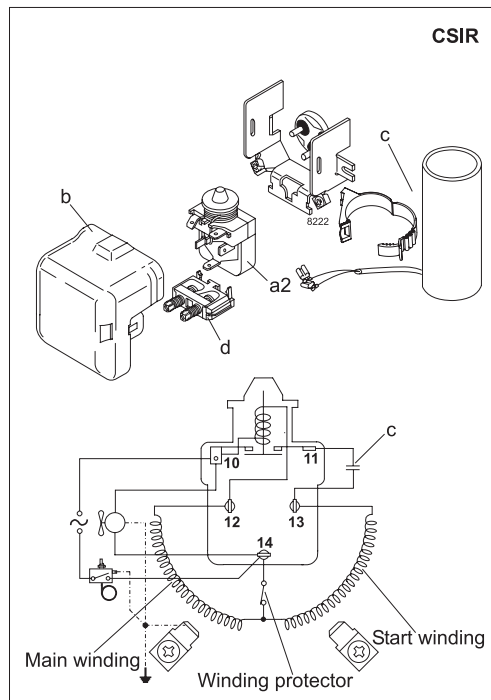

Accessories for	SC12CLX.2 (50/60Hz)	Figure	Code number	Test conditions	EN 12900/ CECOMAF*	ASHRAE LBP*
PTC starting device	6.3 mm spade connectors	a1	—	Condensing temperature	45°C	43.3°C
	4.8 mm spade connectors		—	Ambient temperature	32°C	32°C
Starting relay	6.3 mm spade connectors	a2	117U6019	Suction gas temperature	32°C	32°C
Cover		b	103N2008	Liquid temperature	no subcooling	32°C
Start. capacitor 80 µF	6.3 mm spade connectors	c	117U5017			
Cord relief		d	103N1004			
Protection screen for PTC		g	—			
				Mounting accessories	Code number	
				Bolt joint for one comp.	Ø: 16 mm	118-1917
				Bolt joint in quantities	Ø: 16 mm	118-1918
				Snap-on in quantities	Ø: 16 mm	118-1919

Nidec GA Compressors accepts no responsibility for possible errors in catalogs, brochures, and other printed material. Nidec GA Compressors reserves the right to alter its products without notice. This also applies to products already on order provided that such alterations can be made without consequential changes being necessary to specifications already agreed. All trademarks in this material are the property of the respective companies. Secop and the Secop logotype are trademarks of Nidec Global Appliance Germany GmbH. All rights reserved. www.secop.com